



Filters

Flanges

Pre-Filter

2011 GAS ANALYSIS EQUIPMENT CATALOG

Website: www.apexinst.com
Contact: info@apexinst.com

919-557-7300 or 800-882-3214
Fax: 919-557-7110

Apex Instruments, Inc.
204 Technology Park Lane
Fuquay-Varina, N.C. 27526, U.S.A.

GAS ANALYSIS EQUIPMENT

Gas sampling or constant velocity sampling requires an understanding of Methods 1 through 3, these are basic methods of collecting a sample. Apex offers source sampling solutions to complete your testing needs. The **XC-60 Source Sampler** is designed to extract and trap the samples needed to test for harmful gases. After the sample is collected there are many types of analysis depending on the compound(s) of interest.

Method 3	Gas Analysis for the Determination of Dry Molecular Weight
Method 3B	Gas Analysis for the Determination of Emission Rate Correction Factor or Excess Air
Method 4	Determination of Moisture in Stack Gases
Method 7	Determination of Nitrogen Oxide - Emissions from Stationary Sources
Method 18	Integrated Bag Sampling for Organic Compounds
Method 0030	Volatile Organic Compounds (VOST)
Method 0031	Volatile Organic Compounds (SMVOC or SuperVOST)
Method 0040	Principle Organic Hazardous Constituents (POHCs) using Tedlar® Bags
Method 0051	Hydrogen Chlorine and Chlorine

IRM - Instrumental Reference Methods & Equipment

The US EPA specifies IRM Reference Methods are used to substantiate the accuracy and precision of the CEMS. A **Continuous Emission Monitoring System (CEMS)** is the equipment that is used for the determination of a gas or particulate matter concentration or emission rate using pollutant analyzer measurements, conversion equations, graphs, or computer programs to produce results in units of the applicable emission limitation or standard. CEMS are required under some of US EPA regulations for either continual compliance or when one is exceeding the standards.

Method 3A	Determination of oxygen and carbon dioxide concentrations in emissions from stationary sources
Method 6C	Determination of sulfur dioxide emissions from stationary sources
Method 7E	Determination of nitrogen oxide emissions from stationary sources
Method 10	Determination of Carbon Monoxide Emissions from Stationary Sources
Method 25A	Determination of Total Gaseous Organic Concentration using a Flame Ionization Analyzer

Please feel free to call our friendly sales staff today!

Vance Jones
Domestic Sales,
Customer Service
vjones@apexinst.com

Janet Nichols
Sales Manager
jnichols@apexinst.com

Customer Service
sales@apexinst.com
info@apexinst.com

John Stauber
International Sales
john@apexinst.com

Phone: 919-557-7300 or In the U.S. **800-882-3214**
Monday-Friday, 8:00 a.m. to 5:00 p.m. (Eastern Time)

Fax: Order at your convenience 24 hours a day,
7 days a week **919-557-7110**

Website: www.apexinst.com

Please visit our website for additional product information, new product releases, updated materials, manuals, reference data and valuable links.

ISOKINETIC SAMPLING EQUIPMENT

MERCURY AND GAS SAMPLING SYSTEMS & EQUIPMENT

FLOW, PRESSURE & TEMPERATURE

GAS ANALYSIS EQUIPMENT

Extractive Sampling Equipment.....	3c
Pre-Filters, Flanges, IRM Probe, Probe Assemblies.....	4c - 5c
Filter Assemblies, RATA Sampler, Tri- Sample Probe PMI Dilution Probe & Panel	6c - 8c
Heated Sample Line, CEM Temperature Controllers	9c - 10c
Gas Conditioners, Portable Conditioner, Flow Draws, Gas Analyzers	11c - 14c
Method 3 Orsat Analyzers, Combustion Gas Analyzers, Filter Housings, Condensers	15c - 18c
Gas Analysis Index	19c

ACCESSORIES

APPENDIX

INDEX



CUSTOMER SATISFACTION is guaranteed at **APEX INSTRUMENTS**.

We back up this commitment with extensive knowledge of our products, good communication and an excellent customer service history. Our equipment is designed by experienced stack testers who know what you face when performing compliance testing.

We encourage you to suggest ideas to improve our equipment. We work closely with you, over the long term, to provide the best equipment for your needs.



Hours of Operation:
Monday through Friday from 8:00 am
until 5:00 p.m. (EST).

Apex Instruments, Inc.
204 Technology Park Lane
Fuquay-Varina, NC 27526 USA

In U.S. Call Toll Free:
1-800-882-3214

Local: 1-919-557-7300
fax: 1-919-557-7110

e-mail: info@apexinst.com

www.apexinst.com

Delivery:

Most orders are shipped within 24 hours of receipt. Please allow extra time for custom orders. Shipping times vary according to the requested shipping service. If you have questions about your shipment please email our shipping management at shipping@apexinst.com.

Return Merchandise Authorization

Customers wishing to return items for service or credit need to contact our sales associates for an RMA. Contact by email at sales@apexinst.com or by phone (919) 557-7300 or toll free (800) 882-3214.

Pricing

Prices are published for U.S. customers only. International customers should contact their local distributor. Prices are in U.S. Dollars, FOB shipping point, or Ex Works for International orders. Please confirm current prices by phone, fax or email. Please refer to our price list for a complete list of part numbers and kit configurations.

Payment

For your convenience, MasterCard, VISA and American Express are welcome. Company purchase orders are accepted upon credit approval.



EXTRACTIVE SAMPLING EQUIPMENT

There are several instrumental reference methods (IRM) in 40 CFR Part 60 that are used to measure air pollutant emissions from stationary sources using a continuous instrumental analyzer. These include Methods 3A, 6C, 7E, 10, 20 and 25 to measure oxygen, carbon dioxide, sulfur dioxide, nitrogen oxides, carbon monoxide, and gaseous hydrocarbon organic emissions from stationary combustion sources.

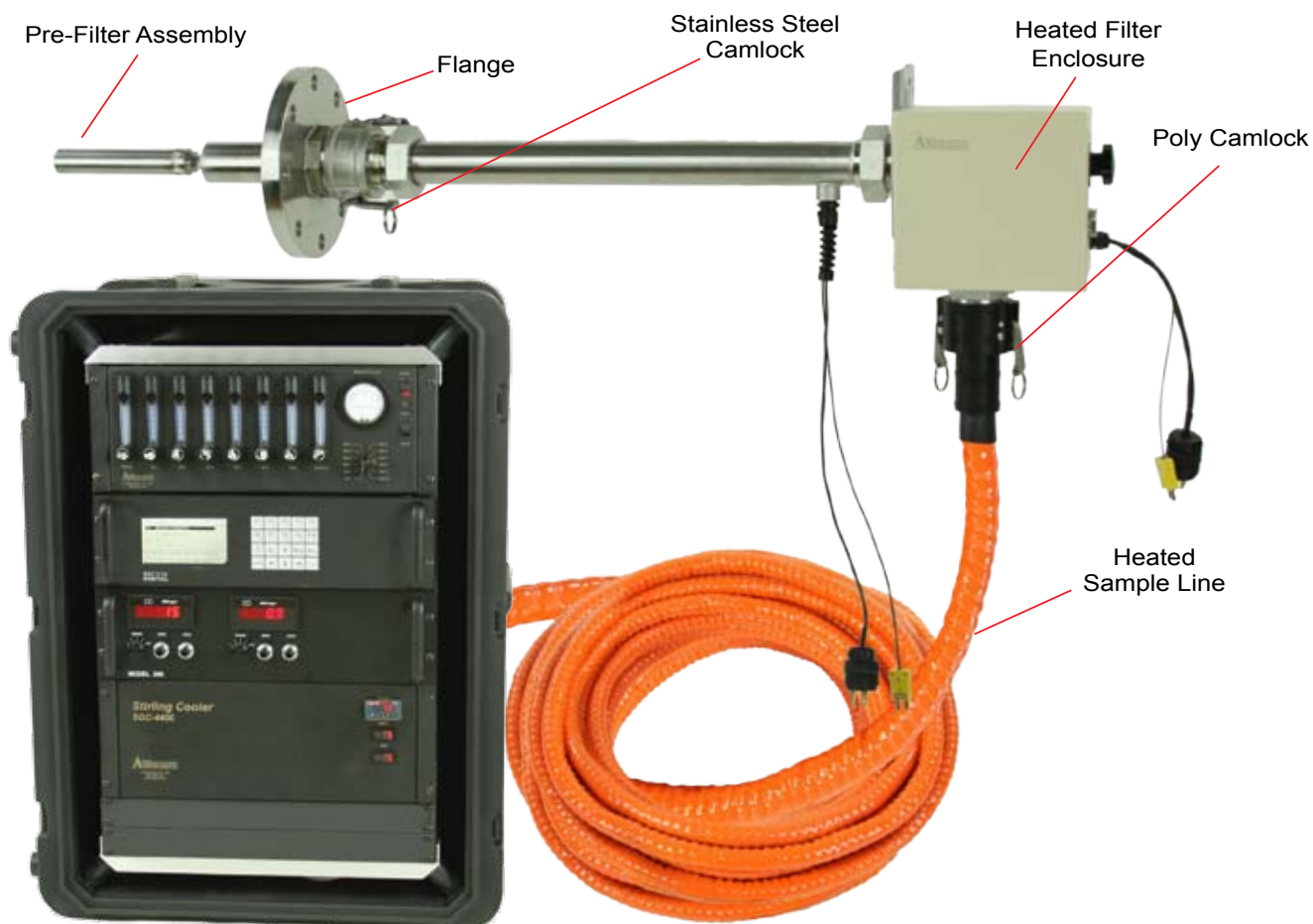

Transportable - IRM System

Apex Systems offer:

- Heated Sample Probe
- Filter
- Heated Sample Line
- Temperature Controller
- Gas Conditioners
- Flow Control Drawer
- Data Acquisition

PRE-FILTERS

Stainless Steel IRM Filter Assembly with replaceable glass fiber filter element that accepts standard 25 m x 90 mm tapered filter thimbles. Particulate shroud to deflect large particulate and increase filter lifespan. Modular, threaded shroud design allows quick and easy replacement of the filter element. Filter retaining ring securely holds filter. Outlet has 3/8" female NPT. Optional Silcosteel coating for low NO_x applications. Replaceable filter elements sold separately.

SFC-2590



SFC-2590
(Shown with
Tube Union
Adapter)

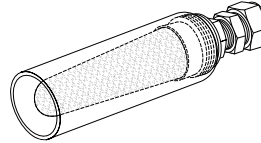

SFC-2590
(Inside View with
GF-2590 element)

Porous Stainless Steel Filters are typically used as a pre-filter for IRM In-Stack Filtration to prevent clogging of filters downstream. Filters have over 18 square inches of a 10 micron filtering surface and can be back flushed with compressed air. Apex also offers an optional particulate shroud for extra heavy dust loadings. These filter assemblies attach to the stack end of the probe liner.

Stainless Steel Pre-Filters

Part #	Description
SSF-64N10	Sintered Stainless Steel Filters, 10 Micron, 6" Length, 1/4" FNPT Fitting
SSF-64N10-P	Sintered Stainless Steel Filters, 10 Micron, 6" Length, 1/4" FNPT Fitting with 1.25" OD Particulate Shroud

Male Straight Connector (Not Included with SSF-64N10 or SSF-64N10-P)

Part #	Description
4MSC4N-S	1/4" Tube Fitting to 1/4" MNPT, Stainless Steel
6MSC4N-S	3/8" Tube Fitting to 1/4" MNPT, Stainless Steel
8MSC4N-S	1/2" Tube Fitting to 1/4" MNPT, Stainless Steel
10MSC4N-S	5/8" Tube Fitting to 1/4" MNPT, Stainless Steel

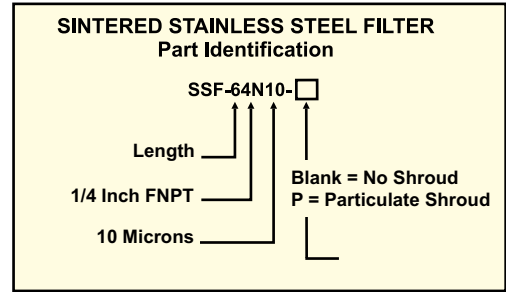

IRM PROBE

IRM Probe Assemblies incorporate the popular heater design from the Method 5 probes so liners can be changed in seconds without disturbing the heater. The separate heater tube provides even heat distribution and isolates the electrical elements from the liner. The probe sheaths are constructed with a 2" stainless steel outersheath with a tube nut welded to the end for attachment to a porous filter or a bored cap. Probes are available in any length from 2' to 20'. The probes are manufactured to accommodate standard wattages or customized for hotter conditions. Add "V" to end of part number for 240 VAC.

All IRM Probe Assemblies are available with 1" or 2" OD Stainless Steel Sheath, 2" OD stainless steel sheath with a heater and a liner made from stainless steel, inconel, quartz or glass (120 VAC/60 Hz). Classic 1" OD stainless steel sheath is also still available.

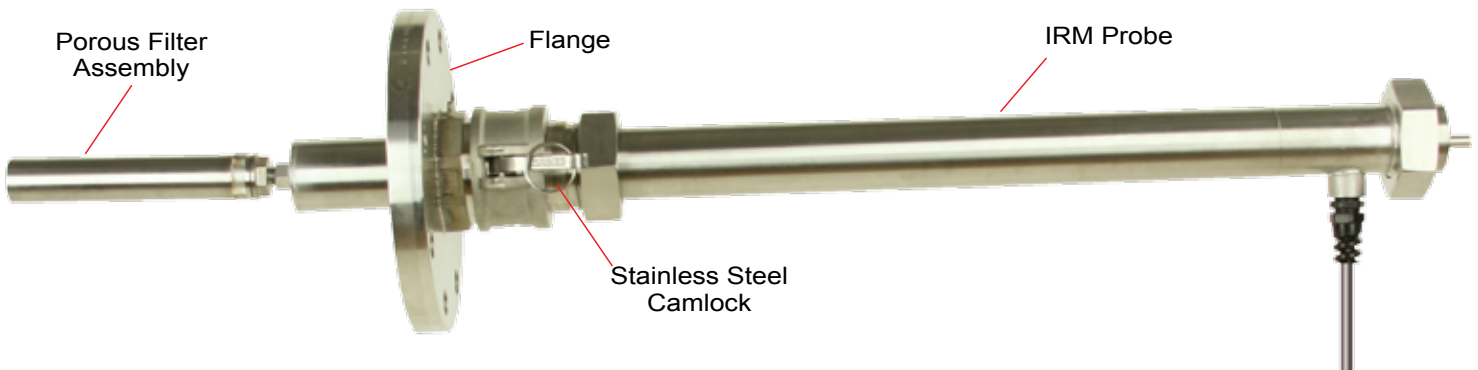

IRM System

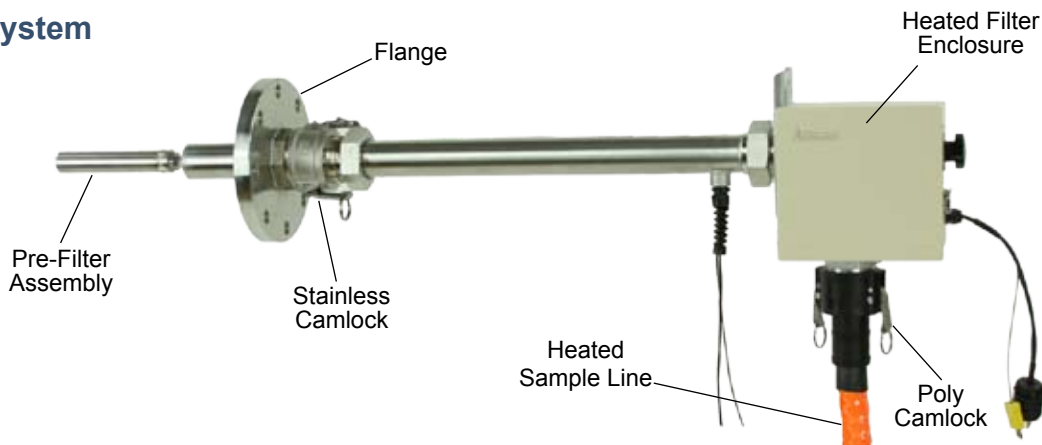

IRM 2" Stainless Steel Probe Assemblies with Stainless Steel Liner



Model PC □-□S-□2	2" OD	2" OD	2" OD	1" OD
Nominal Length	4=1/4"	6=3/8"	8=1/2"	1" Classic
3'	Call for Additional Information			
4'				
6'				
8'				
10'				
12'				

**CEM PROBE
Part Identification**

P C □ □ - □ □ - □ □

Component
 Blank = Assembly
 H = Heater
 L = Liner
 S = Sheath

Liner Sizes
 4 = 1/4
 6 = 3/8
 8 = 1/2
 10 = 5/8

Length in feet
 4 = 4 foot
 6 = 6 foot
 etc.

Liner Material
 G = Glass
 S = Stainless Steel
 Q = Quartz
 I = Inconel

Sheath
 Blank = 1"
 O2 = 2"

IRM Probes are available with Stainless Steel or Inconel Sheaths, Heated or Unheated, & with 1/4, 3/8, 1/2, or 5/8 IN O.D. Liners. Additional configurations & sizes are available. CALL FOR PRICING.

IRM Ceramic Probe Heaters are recommended for temperatures over 500°F. (only available with 2" overshoot). Call for Pricing on Special Inconel & Ceramic Hi-Temp Heaters.

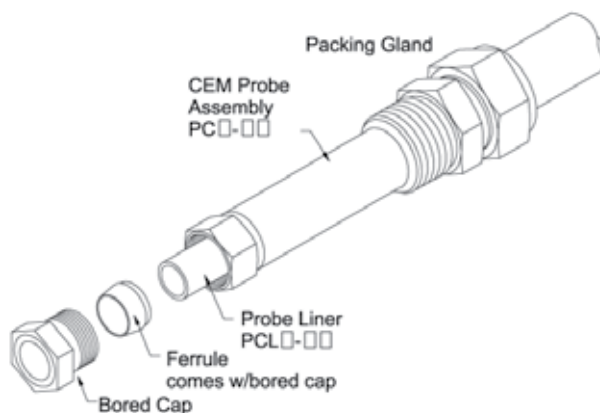

[Link to Pipe Flanges](#)

FILTER ASSEMBLIES

The oven can accept an 18' long heated probe with 2" diameter sheath. The probe uses a replaceable 3/8" stainless steel liner. The oven features a lightweight construction, with a rugged strip heater, 1/2" insulation, high temperature and stainless steel hardware. Type-K thermocouple jacks are used for monitoring probe and oven temperature. A dual channel digital thermometer is recommended.

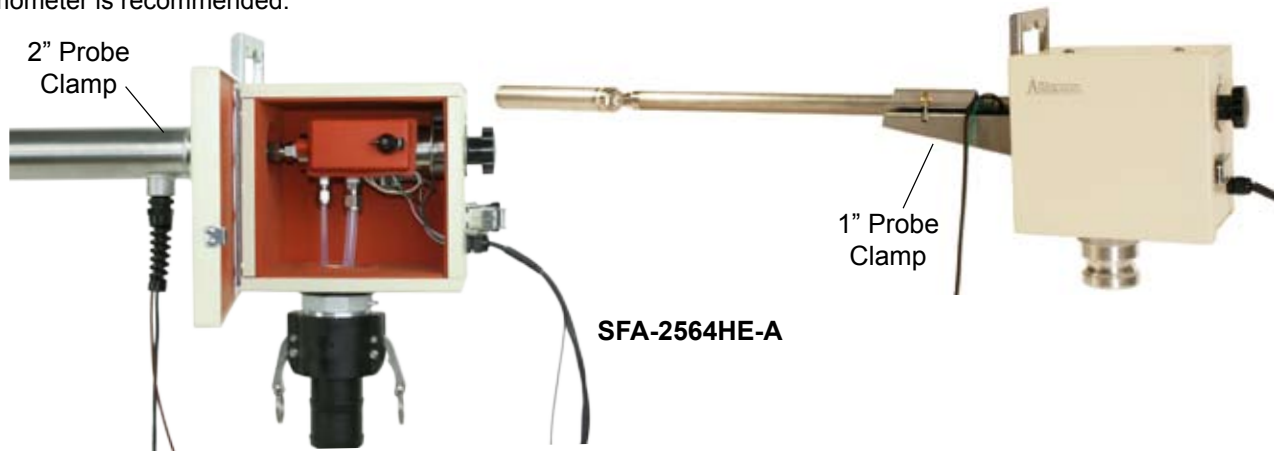

FILTER HOLDERS

Product	Description
SFA-2564	2 Port Filter Assembly, 25x64mm, Stainless Steel Filter Assembly, Accepts 25X64mm Filter, One 1/4" and 1/8 FNPT Ports, Accepts GF-2564 filter elements
SFA-2564-4N2	Two 1/4" FNPT Port Stainless Steel Filter Assembly, Temp Rating 400°F, Accepts 25X64mm Filter 1 IN PC- 1 Probe Clamp, Standard Male Plug, 110V
SFA-2564-4N3	Three 1/4" FNPT Port Stainless Steel Filter Assembly, Temp Rating 400°F, Accepts 25X64mm Filter
SFA-2564-4N3P	SFA-2564 Three Port 1/4" NPT Inlet Filter
SFA-2564-4N6	Six Port Stainless Steel Filter Assembly, Temp Rating 400°F, Accepts 25X64mm Filter, for RATA Sampler
SFA-2564-4N6P	SFA-2564 Six Port Inlet Filter, SFA-2564, Total Five 1/8" NPT & One 1/4" NPT
SFA-2564HE-A	Heated SFA-2564 CEM Filter Assembly & Silicone Insulated Enclosure, Accepts GF-2564 Filter Elements,
SFA-2564HE-AT	Thermostat Controlled Heated SFA-2564 CEM Filter Assembly and Silicone Insulated Enclosure, Accepts GF-2564 Filter Elements, 1" PC- 1 Probe Clamp, Standard Male Plug, 110V
SFA-2564HE-AV	Heated SFA-2564 CEM Filter Assembly and Silicone Insulated Enclosure, Accepts GF-2564 Filter Elements, 1" PC- 1 Probe Clamp, Standard Male Plug, 240V
SFA-2564HE-B	Heated SFA-2564 CEM Filter Assembly and Silicone Insulated Enclosure, Accepts GF-2564 Filter Elements, 2" Probe Clamp, Standard Male Plug, 110V. ** Cable Entry Seal sold separately **

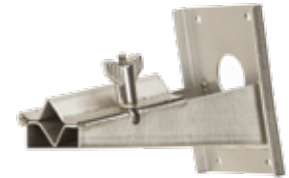

Probe Clamp



SFA-2564

REPLACEMENT FILTER ELEMENTS

Product	Description
GF123270K	Filter Cartridge, Borosilicate glass microfiber with Fluorocarbon resin binder, 12 x 32 mm, Maximum Temperature 300°F, 10/pk
GF123270S	Filter Cartridge, Borosilicate Glass Microfiber with inorganic binder, 12 x 32 mm, Maximum Temperature 900°F, 10/pk
GF125770K	Filter Cartridge, Borosilicate Glass Microfiber with Fluorocarbon resin binder, 12 x 57 mm, Maximum Temperature 300°F, 10/pk
GF125770S	Filter Cartridge, Borosilicate Glass Microfiber with inorganic binder, 12 x 57 mm, Maximum Temperature 900°F, 10/pk
GF256470K	Filter Cartridge, Borosilicate Glass Microfiber with Fluorocarbon resin binder, 25 X 64mm, Maximum Temperature 300°F - 10/pk,
GF256470K	Filter Cartridge, Borosilicate Glass Microfiber with Fluorocarbon resin binder, 25 X 64mm, Maximum Temperature 300°F - 10/pk,
GF2517870K	Filter Cartridge, Borosilicate glass microfiber with Fluorocarbon resin binder, 25 x 178 mm, Maximum Temperature 300°F, 10/pk
GF2517870S	Filter Cartridge, Borosilicate Glass Microfiber with inorganic binder, 25 x 178 mm, Maximum Temperature 900°F, 10/pk

Apex Instruments stocks 2 types of Cartridges:

K-type with Fluorocarbon Resin Binders for Testing in Locations where Highly Reactive and/or Corrosive Gases are Present, and S-type Cartridges with Inorganic Resin Binders for Filtering Gases at Temperatures up to 900°F.

TRI-SAMPLE PROBE

The Apex Instruments **Tri-probe** allows the simultaneous sampling and monitoring from three distinct sampling points. The manifold and filter unit comes with six holes, for a unique design made for RATA sampling. The user can now extract samples without moving the probe to different traverse points. Traverse points acquire representative samples

The Tri-Probe has multiple probe extension options to meet the specifications of any test site.

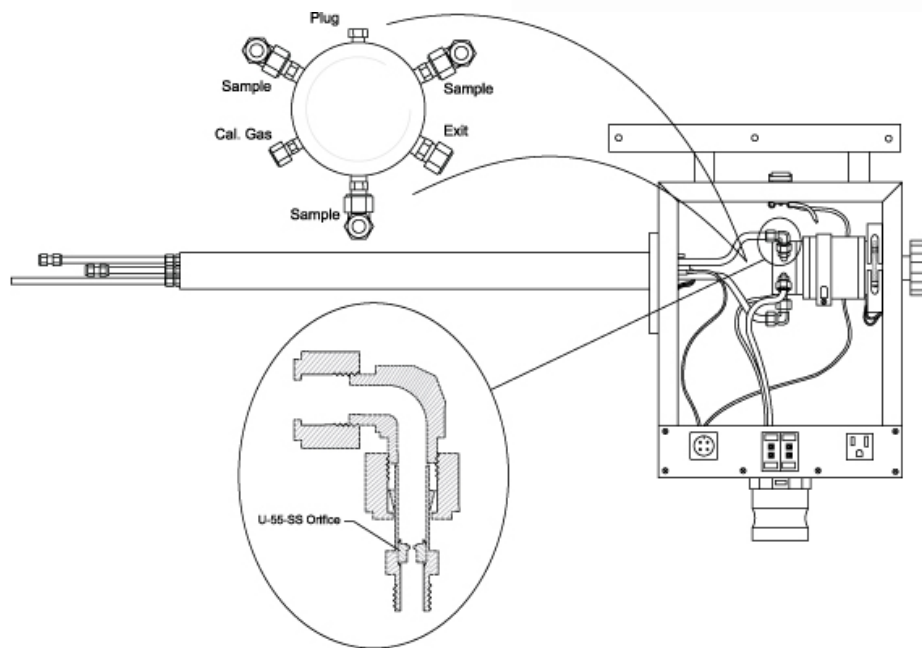

GAS SAMPLE FILTER HOUSINGS

Traditional in-line gas sample filters are used to remove particulate prior to analyzing to protect your valuable equipment. Replacement filters not included.



SFA-116IL



SFA-137G



TFA-122P



760N-2

Filter Housing

Product	Description	Temperature Rating	Pressure	Filters
SFA-116IL	Stainless Steel, 1/4" FNPT, 3" Long	200°C (400°F)	5000 PSIG	12 x 32mm, GF123270K, GF123270S
SFA-H130S-TE	Stainless Steel, Heatable, 4.57" Long, 1/4" End Ports	200°C (400°F)	30 PSIG	25 x 64mm, GF256470K, GF256470S
SFA-137G	Glass Filter, T-Type, 1/4" FNPT, 4.49" Long	200°C (400°F)	150 PSIG	25 x 64mm, GF256470K, GF256470S
TFA-122P	PTFE, 1/4" FNPT, 3.86" Long	150°C (300°F)	100 PSIG	12 x 57mm, GF125770K, GF125770S
760N-2	Nylon, Side Ports, 1/4" FNPT, 5.51" Long	50°C (120°F)	100 PSIG	25 x 64mm, GF256470K, GF256470S

PMI Dilution Probe

PMI Dilution Probe

for In-Situ Sampling Conditioning of Stack Gases

The PMI-3000 Dilution Probe performs four critical functions to prepare the sample from the stack or process, so it can be measured accurately and precisely by the analyzer. The probe uses an air driven aspirator which extracts the sample from the stack or process. It is then passed consecutively through coarse and fine particulate filters, a pre selected glass or metal critical orifice, and finally diluted with the air from the aspirator. This process has now reduced the dew point of the sample to below that of the ambient air, preparing the sample so that it can be transported via an unheated line to the analyzer up to 300 feet away.

There are two models of the PMI-3000 Dilution Probe available, differing only in the type of mounting flange. Model PMI-3200, equivalent to the EPM 0797.302, has a 1.8" flange drilled and tapped with four mounting holes. Model PMI-3300 (equivalent to EPM 0797.303) has a threaded flange for easy use with extension tubes.



PMI-3000 / PMI-3200 / PMI-3300 Dilution Probe

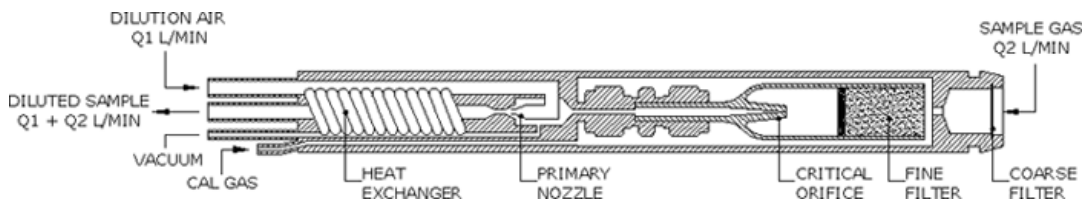

Features

- Low Cost Installation, Maintenance and Operation
- Low Extractive Flow Rates, Promotes Long Filter Life
- Made of Corrosion Resistant Materials
- Can be used in Explosion Proof Areas
- No Requirement for Heated Sample Line
- No Moving Parts Anywhere in the System
- Easy Dynamic In-Situ Calibration of Dilution System
- Diluted Sample is Transported at Positive Pressures
- Can be Used with Any Existing Ambient Air Analyzer
- Manual or Optional Automatic Blow Back, Back Flushes Coarse Filter PMI-3000 Probe

Specifications

A) Material of Construction:

- The Eductor Housing, Mantle, Filter Cap and Flange (the "Wetted Parts") are Fabricated from Inconel® 600, a Corrosion Resistant Nickel-Chromium Alloy.
- The Heat Exchanger and the Four Inlet/Outlet Tubes are Fabricated from Grade 316 Stainless Steel.

B) Maximum Operating Temperature:

- 750° F (400° C) with standard glass orifice.
- 1,100° F (600° C) with special metal orifice – call PMI for details.

C) Dimensions:

- Vacuum and Calibration lines 0.125" OD.
- Dilution Air and Sample out lines 0.25" OD.
- All lines supplied with 0.25" OD tube fitting attached.

Apex Instruments Dilution Panel

Features

- High Accuracy
- High Resolution Regulation
- Blow-Back Control
- Calibration Circuit

ADP-007



ADP-007

Specifications:

- Application EPM Thermo, PMI Type In Situ Type Probes.
- Remote (Dry Contract) for Cal and Blow Back.
- Sample, Bypass and Cal Gas Rotometers.
- Precision Air Pressure Regulator.
- 4 U (19" W x 7"H)) Case Rack Mountable (20 lbs.)
- Front Panel Air Pressure, Vacuum and Blow Back Gauge's
- 110 / 220 VAC

APEX Pro-Series Heated Sample Line

HSLP-64-100

The Apex Instruments Heated Sample Lines are designed for the professional stack tester that needs a rugged lightweight flexible sample line that can handle the abuse of IRM sampling day after day. The standard core includes one 3/8" PFA tube for the sample and one 1/4" tube for introducing calibration gas at the probe. Both lines have stainless steel over-braid and swaged tube stubs attached.

Apex Pro-Series Heated Sample Line, 100 FT, 3/8 IN & 1/4 IN PFA stainless steel Overbraid Lines, Nomex®/Aramid Felt Insulation, Non-Lead Stabilized Vinyl Elastomer Extruded Jacket (orange). Requires Temperature Controller. Apex Offers temperature controllers for use with the Pro-Series.

HSLP-64-100

100 FT Heated Sample Line 3/8 IN & 1/4 IN PTFE lines, Foam Insulation w/ Oversheath.

HSLP-64-100



Apex Pro-Series

*Designed for
Portable Systems*

Higher Temperature Units are Available.

Inquire for Custom Lines Manufactured to your Specification.

Features

- PFA Tubing with Stainless Steel Overbraid
 - Heated Sample; 3/8"
 - Unheated Cal-Gas; 1/4"
- 1/2" Nomex® Insulation
- Non-Lead Stabilized Vinyl Elastomer Extruded Orange Durable Jacket for High Visibility, Flame Retardant
- Lightweight & Flexible
- Bend Radius: 10"
- Stainless Steel Tube Stubs

Specifications

- Spiral wound heating element for uniform heat distribution
- Power Density 23 Watts/ft.
- Supply voltage 120V or 240V
- Maximum temperature rating 400^o (200^oC)
- Tube maintenance up to 370^oF (200^oC) at 0^oF
- Type K thermocouple for control sensor
- Nominal O.D. 1.75"
- Weight 55 lb. for 100 ft.
- Maximum operating pressure: 300 psi

A temperature controller MUST be used on this bundle in order to prevent it from overheating.

Apex offers temperature controllers for use with the Pro-Series

Temperature Controller

Heavy Duty (High Output) Single Station Digital Temperature Controller, 20A Max, 120V.

ICH-901



ICH-901

Temperature Controller

CEM TEMPERATURE CONTROLLERS (4 different models)

Apex Instruments offers a choice of one or two station **Temperature Controllers** in three different styles of digital display controllers. All of our temperature controllers have a panel mounted circuit breaker and a separate solid state output relay for high output reliability. The heavy duty controllers have a panel mounted circuit breaker and a separate solid state output relay for high output reliability. Our heavy duty controllers have a separate slow-blow 25 amp fuse that is panel mounted for easy access and are typically used with 50 to 100 foot heated sample lines. These temperature controllers can be used for (CEM) in any application where there is a need to control temperature. The dual station controllers can be used in configurations that require control of any two heated devices such as the probe/oven combination or the probe/heated sample line.

Features

- Fixed or Adjustable Set Points
- Four Character LED Display
- Fahrenheit or Celsius Operation with Indication
- Sensor Break Protection
- Microprocessor Based Technology



ICS-901M

Compact Rugged



ICS-901M Front View

Single Station Digital Temperature Controller

Single Station Digital Temperature Controller, Solid State Output Relay, 10A Max, 120V

ICS-901M

Temperature Controllers

Product	Stations	Duty	Controller	Output	Power
ICS-901	One-Station	Standard	Digital	15 Amps	120V
ICS-902	Two-Station	Standard	Digital	15 Amps	120V
ICH-901	One-Station	Heavy	Digital	20 Amps	120V
ICS-CV1*	One-Station	Standard	Analog	Internal Relay	120V

*Add 'C' for Celsius or 'F' for Fahrenheit. Comes with press-to-set digital indicator in diecast aluminum enclosure. 240 volt operation is available for all controllers. Add "V" to end of part number. (e.g. ICS-901MV).

Single and Dual Temperature Controller Features

- External Vertically Mounted Aluminum Heat Sinks for Better Heat Transfer from Relays.
- Compact Size: 8.5" x 7.25" x 6.5" (21.6 cm x 18.4 cm x 6.5 cm)
- Oversized Solid State Relays - 25 Amp (50 Amp Available for High Output)
- Type K Thermocouple Input (Other Modules Available Upon Request)
- Standard Receptacles for Power Output
- Alternate Connectors Available (i.e. 4-Pin Circular Connectors)



ICH-901



ICS-902

Single Station Digital

Heavy Duty (High Output) Single Station Digital Temperature Controller, 20A Max, 120V.

ICH-901

Dual Station Digital

Dual Station Digital Temperature Controller, Solid State Output Relay, 10A Max, 120V.

ICS-902

ICS-CV Station Digital Temperature Controller

The Apex ICS-CV temperature controllers are basic on-off microprocessor based temperature controllers mounted in a die-cast aluminum enclosure. The temperature set-point is easily set by pushing the button and rotating the dial to the desired temperature on the LED display. Actual temperature is continuously displayed.



ICS-CV1

Digital Display Temperature Controllers

- Accuracy to $\pm 0.25\%$ of Span
- 1/32 DIN Controller

Single Station Analog Temperature Controller with Internal Relay, 120V, Press-to-Set Digital Indicator in Diecast Aluminum Enclosure, Degree C Readout. **ICS-CV1F**

Single Station Analog Temperature Controller with Internal Relay, 120V, Press-to-Set Digital Indicator in Diecast Aluminum Enclosure, Degree F Readout. **ICS-CV1C**

Temperature Controllers

Product	Stations	Duty	Controller	Output	Power
ICS-CV1*	One-Station	Standard	Analog	Internal Relay	120V

GAS CONDITIONERS

SGC-4400 RACK MOUNT STIRLING GAS CONDITIONER / COOLER

The Apex Instruments SGC-4400 Stirling Gas Conditioner is specifically designed for removing moisture from process gas samples prior to gas analysis. This new style gas cooler uses an industrial grade super efficient Free Piston Stirling Cooler (FPSC) for cooling the gas to a constant dew point. The FPSC has several advantages over the conventional Rankine Compressor or Thermoelectric Refrigeration units. For example, the FPSC cooler module uses a small quantity of environmentally safe helium gas as a refrigerant. The module is hermetically sealed in a stainless steel casing allowing for fast and easy installation and replacement when necessary. 120VAC, Dimensions (HxWxD): 17" (43.18 cm) x 16" (40.64 cm) x 7" (17.78 cm). Weight: 28 pounds (12.7kg).

SGC-4400

Features

- Environmentally Friendly
- Uses Helium (He) as a Refrigerant (Natural, Non-flammable, Inert)
- No CFC's
- Energy Saving High Efficiency, Super Cooling Capacity
- Can Reach -50°C
- 6x Efficiency of Thermoelectric (Peltier) Coolers
- FPSC Uses Less than 40w of Electricity
- 12 VDC Power Supply Digital Temperature Control
- Constant Set Temperature Environmentally Friendly
- 19" Rack Mount
- Weight - 28 lbs
- Dimensions - 17" x 16" x 7"

Specifications

- Digital Temperature Control $\pm 1^\circ\text{C}$, LED Display
- Cooling Capacity > 40 watts
- Dual Path Chiller Block Anodized Aluminum
- Reverse Flow Condensate Separator C276 Alloy - 1" O.D. x 4" Active Zone
- Flow Rate two-stage configuration: 4 lpm @ 15% moisture
- Dew Point 40°F (> 1% H₂O vapor by volume)
- Alarm Output - optional Switched 6VDC
- Freeze Protection 80w heater
- Ambient Operating Temperature 0 to 50°C (32°F to 122°F)
- Peristaltic Drain Pump Dual Head / size 15 tubing
- Inlet / Outlet Fittings 1/4" tube unions
- Power Requirements 120VAC / 2.5 amps
- 19" Rack Mount
- Weight - 28 lbs
- Dimensions - 17" H x 16" W x 7" D

SGC-4400
(Front & Back View)



SGC-4000HGP RACK MOUNT STIRLING GAS CONDITIONER / COOLER

The Apex Instruments SGC-4000HG Stirling Gas Conditioner is specially designed for removing moisture and acid gases from flue gas samples. This new style gas chiller uses an industrial grade super efficient Free Piston Stirling Cooler (FPSC) for chilling the gas to a constant dew point. The FPSC has several advantages over the conventional Rankine Compressor or Thermoelectric Refrigeration units. For example, the FPSC chiller module uses a small quantity of environmentally safe helium gas as a refrigerant. The module is hermetically sealed in stainless steel casing allowing for fast and easy installation and replacement when necessary.

SGC-4000HGP

Available in Rack Mount or Portable versions

Environmental Friendly

- Uses Helium (He) as a Refrigerant (Natural, Non-Flammable, Inert)
- No CFC's
- Energy Saving

High Efficiency, Super Cooling Capacity

- Can reach -50° C
- 6x Efficiency of Thermoelectric (Peltier) Coolers
- FPSC Uses Less than 40w of Electricity
- 12v DC Power Supply Digital

Temperature Control

- Constant Set Temperature
- Temperature Alarm Output

Weight and Dimensions

- Portable with Collection Cabinet Weight 37 lbs. without Sorbent Dimensions: 22"x13.5"x23.75"
- 19" Rack Mount
- Weight 25 lbs. Dimensions: 17"x16"x7"



SGC-4000HGP

Specifications

- Digital Temperature Control +/- 1 Degree C, LED Display
- Cooling Capacity >40 Watts
- Dual Path Cooling Block Anodized Aluminum
- Condensate Bottle 1000 ml (Plastic Coated Glass)
- Reverse Flow Condensate Separator Silcosteel®-CR Treated Stainless Steel 1" OD x 4" Active Zone
- Maximum Flow Rate 2 liters per minute @ 20% H₂O/Channel
- Alarm Output Switched 6v DC
- Freeze Protection 80w Heater
- Ambient Operating Temperature 0 to 50° C
- Power Requirements 120v AC/2.5 amps

Apex Instruments Flow Drawer

AFD-510

The Apex AFD-510 is designed to be an easy, convenient, and compact way to control the flow of both stack and calibration gases.

This new panel can flow gas to either the analyzer bank (Direct calibrations) or the probe (System calibrations), and has both automatic and manual controls.

This unit has been designed with simplicity in mind. It has the same common solenoids and a simplified wiring protocol.

The calibration gas in use is identified by a LED along with which mode you are in and if you are sampling or calibrating. One big benefit of the Apex Instruments AFD-510 is that in sampling mode all solenoids are at "rest" which greatly extends the life of the unit.

AFD-510

Features

- 11 Calibration Gas Channels (Including Zero and Span)
- 5 Output or Analyzer Channels
- 8 Valved Rotometers for Fine Flow Control/Adjustment
 - 5 Analyzer Rotometers
 - 1 Vent Rotometer
 - 1 Probe Calibration
 - 1 Sample Flow Rotometer
- 19" Rack Mountable
- Designed for Easy Maintenance and Repair
- Manual or Automatic Operation



AFD-510

Specifications

Input Cal-Gas Channels:

Flowmeters Standard: Sample 0-10 LPM
Vent 0-10 LPM

Output Gas Channels:

Flowmeters Available: 0-0.5 LPM
0-1.0 LPM
0-2.5 LPM
0-5.0 LPM

Voltage: 110.220 VAC, 50/60 Hz

Power: 25 Watts

Mounting Dimensions: 4U, 19" Rack Mount, 7" Height x 19" Width x 18" Depth

Weight: Approximately 24 lbs

Pressure Gauge: 0-15 psi

Connections: 1/4 Inch Stainless Steel Tube Union



AFD-510 Shown in Portable Gas Analysis Unit

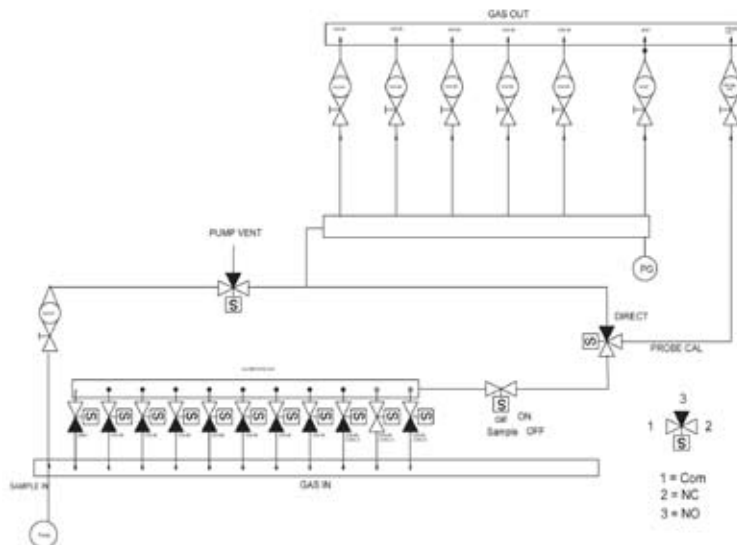



AMETEK Process Instruments

Manufacturer of individual analyzers and turn-key CEM rack systems for dry-basis monitoring of pollutants in flue gases. Analyzers are available for use in new or existing extractive CEM rack systems (or other instrument racks) where the sample gas entering the analyzer is non-condensing at ambient temperatures. www.ametekpi.com.



California Analytical Instruments

California Analytical Instruments, Inc. (CAI) provides quality gas analyzers and systems used in Industrial, Environmental, Process and Automotive Emissions applications. CAI products include Infrared Analyzers; Chemiluminescence Analyzers, Oxygen Analyzers, Flame Ionization Analyzers, UV Fluorescence Analyzers, FTIR, Integrated Systems, Specialty Products, Photoacoustic IR Analyzers. www.gasanalyzers.com.



BUHLER Technologies

A broad range of applications like boiler trim, emission monitoring, ammonia slip monitoring, combustion efficiency, LEL warning indication or inner atmosphere control require analyzers with different measuring principles. Bühler offers optical, paramagnetic and zirconium technologies as well as tuned diode laser (TDL) gas analyzers. www.buhler-technologies.com/gas_analysis/products/analyzers.



BRAND GAUS

NOx, O2 and NOx-O2 gas analyzers specifically designed for use in continuous emissions monitoring systems (CEMS) for gas turbines; designed for reliability and simple operation; with industrial interfaces for continuous visible diagnostics and intuitive calibration without the use of delicate character displays or complicated menu systems. www.brandgaus.com.



ECOM

ECOM America Ltd., manufactures portable emission / combustion analyzers for many applications. From single gas Oxygen and Carbon Monoxide analyzers for flue gas testing to multi-gas analyzers measuring Oxygen, Carbon Monoxide, Nitric Oxide, Nitrogen Dioxide, Sulfur Dioxide, & Hydrocarbons offered in several configurations, we have instruments for most combustion applications. Several models are approved and recognized by Regional, State, and Federal Environmental and Air Quality Regulatory Agencies ECOM. www.ecomusa.com.



ENVIRONICS Analytics

Known for computerized gas flow instrumentation; especially gas mixing technology, based on very precise control of thermal mass flow controllers, combined with Environics computerization and calibration results in improved accuracy to +/- 1% of setpoint. www.environics.com.





TELEDYNE INSTRUMENTS (API)

TAPI offers products for continuous emissions monitoring, including: Ultraviolet Absorption Analyzers, Paramagnetic Analyzers, Infrared Gas Filter Correlation Analyzers, Nondispersive Infrared (NDIR) Analyzers, Ultraviolet Fluorescence Analyzers, Chemiluminescence Analyzers.

www.teledyne-api.com/overview.asp



VIG INDUSTRIES

Offers microprocessor controlled hydrocarbon analyzers; Dual or Single Channel (FID) flame ionization detector based (GC) gas chromatography, (VOC) volatile organic compounds, and (THC) total hydrocarbon analyzer systems. www.vigindustries.com/products.htm



SERVOMEX

Known for paramagnetic sensing technology and the development of zirconia, photometric, thick film and plasma technologies. The result is high-performance, cost-effective gas analysis, delivered through a portfolio of dependable products ranging from portable gas analyzers to complex process solutions. www.servomex.com/servomex/web/web.nsf/en/servopro-1440



Bacharach

Bacharach, Inc. is a world leader in the design, manufacture, and service of advanced equipment for the measurement and detection of gases and liquids. The company's extensive product line includes instruments that detect, measure, and record combustion and environmental gases, temperature, relative humidity, air velocity, and other air quality and safety parameters. A full line of refrigerant recovery equipment for residential, industrial, and automotive applications further extends Bacharach's family of products. www.bacharach-inc.com



Nova

Nova Analytical Systems Inc. has been designing and manufacturing dependable gas analysis equipment for over 30 years. Nova offers portable gas analyzers, continuous gas analyzers and sample conditioning equipment for industrial applications. Nova's integrated approach to design and manufacturing allows us to configure our products to suit each application, while still being able to offer the best price, long-term reliability and proven technology in each analyzer. www.nova-gas.com



METHOD 3 ORSAT ANALYZER

Method 3 determines CO₂ and O₂ concentrations and dry molecular weight of a sample from an effluent gas stream. The gas sample is analyzed for CO₂ and O₂ on a gas absorption basis, results are expressed in percentage units. For dry molecular weight determination, either an Orsat or a Fyrite analyzer may be used for the calculations.

The **Orsat Analyzer Train** is designed specifically for Method 3, for analysis of integrated or grab bag samples collected in Tedlar® bags. A liquid filled leveling bottle moves the integrated sample through a graduated glass burette and absorption pipettes containing absorbing reagents. The resulting changes in volume measure percent of O₂, CO₂ and CO. The burette is water jacketed for temperature stability.

VSC-33



Squeeze Bulb Pump

The heavy wall rubber **Squeeze Bulb Pump** with stainless steel valves and connections can be used for gas sampling, pressure source for calibrations and leak tests, and for conditioning probes and sample lines.

A-350

Orsat Accessories

Model	Description
OG-1V/18	Burette, with 3-way Valve and Water Jacket, PTFE Valve Body, 100 mL, Scale 0-30% x .01
OG-2	Aspirator Bottle
OG-5V	Contact Pipette, Valved, Insert Only
OG-5B	Pipette Bottle with Hose Barb
GA-18C	Solid Cap with #18 Threads and Seal
GA-30B	Bored Cap with #30 Threads, 22 mm ID
GA-30S	Silicone Seal Ring #30 Threads, 22 mm ID
TB-3V-P	Tedlar® Bag, Three Compartment with three Poly Valves
TR-5/3	Black Rubber Tubing, 5/16" OD x 3/16" ID, per foot
VC2-50	VersaCase Clamp, 50 mm with Knurled Brass Thumb nuts
VSB3	VersaCase 3, with Hinged, Removable Doors and Mounting Rail
VSB2-MP	VersaCase Mounting Plate

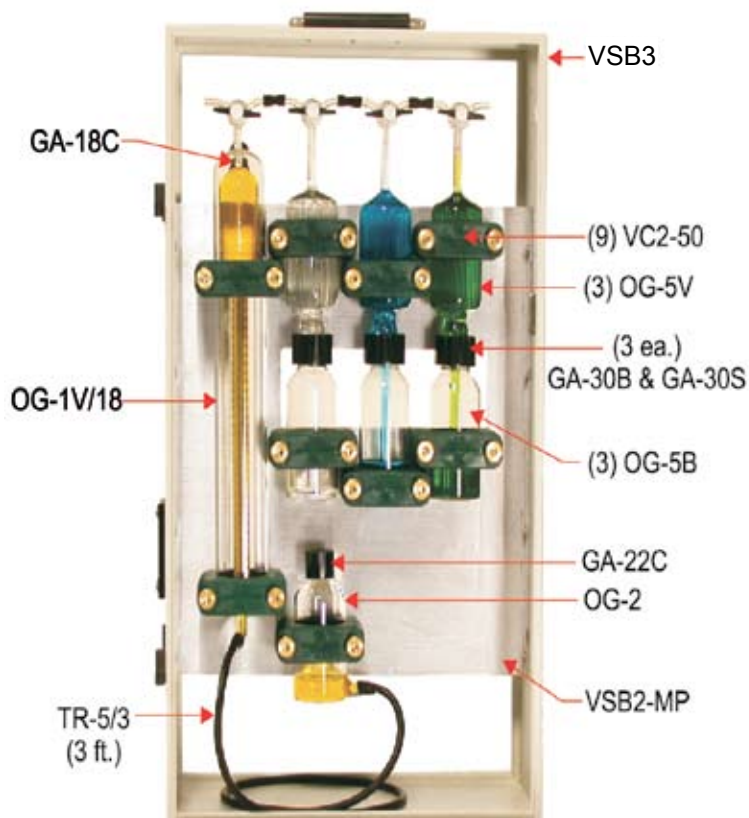

Packing List

Replacement Fluids

Burrell Oxisorbent solution for determining oxygen in gas analysis, 8 oz bottles.

B39-710

Burrell Cosorbent, solution for determining Carbon Monoxide in gas analysis, 8 oz bottles.

B39-720

Burrell Disorbent solution for determining Carbon Dioxide in gas analysis, 16 oz, bottles.

B39-730

**Domestic Delivery only. Sold by case (12 bottles per case).
Drop shipped by vendor due to Hazardous Classification.**

COMBUSTION GAS ANALYZERS

FYRITE® GAS ANALYZERS

Fyrite® Gas Analyzers are fast, accurate and easy to use instruments for measuring and analyzing carbon dioxide or oxygen. Fyrite® Analyzers are available for either CO₂ or O₂ analysis. Fyrite® Indicators have a broad range; they may be exposed to ambient temperatures from -34° to 65°C (-30° to 150°F), and gases up to 450°C (850°F) may be tested with standard aspirator sampling equipment. Single analyzers and additional ranges are available along with refill and repair kits. Call for details.



Fyrite® CO²

Duplex Kits

Model	Description
B10-5020	CO ₂ & O ₂ Fyrite® Gas Analyzer, CO ₂ Range 0-20%, O ₂ Range 0-21%
B10-5021	CO ₂ & O ₂ Fyrite® Gas Analyzer for Export, CO ₂ Range 0-20%, O ₂ Range 0-21%- EXPORT ONLY.

USA Kits CO₂ Testing

Model	Description
B10-5000	CO ₂ Fyrite® Gas Analyzer, Range 0-20%
B10-5032	CO ₂ Fyrite® Gas Analyzer, Range 0-60%

Export Single Kits CO₂ Testing

Model	Description
B10-5001	CO ₂ Fyrite® Gas Analyzer, Range 0-20%

Repair Kits

Includes a bottle of Fyrite® fluid, valve plunger gasket, top gasket, screws, diagram and envelope of filtering material.

Model	Description
B11-7052	CO ₂ Fyrite® Gas Analyzer Repair Kit, Range 0-20% + 60%
B11-7054	O ₂ Fyrite® Gas Analyzer Repair Kit, Range 0-20% + 60%

O₂ TESTING

Model	Description
B10-5011	O ₂ Fyrite® Gas Analyzer, Range 0-21%
B10-5046	O ₂ Fyrite® Gas Analyzer, Range 0-60%

O₂ TESTING

Model	Description
B10-5012	O ₂ Fyrite® Gas Analyzer, Range 0-21%

Refill Kits

Includes two Bottles of Fyrite® Fluid, top gasket, screws and envelope of filtering material.

Model	Description
B11-7047	CO ₂ Fyrite® Gas Analyzer Refill Kit, Range 0-20% + 60%
B11-7050	O ₂ Fyrite® Gas Analyzer Refill Kit, Range 0-21% + 60%

Fluids

Model	Description
B10-5057	CO ₂ Fyrite® Fluid , Range 0-20% + 60%, 3 (2oz.) Bottles per Case
B10-5060	O ₂ Fyrite® Fluid , Range 0-20% + 60%, 3 (2oz.) Bottles per Case

For more information on Bacharach Products visit:
www.bacharach-inc.com

GAS SAMPLE FILTER HOUSINGS

Traditional in-line gas sample filters are used to remove particulate prior to analyzing to protect your valuable equipment. Replacement filters not included.



SFA-116IL



SFA-137G



TFA-122P



760N-2

Filter Housing	Product	Description	Temperature Rating	Pressure	Filters
	SFA-116IL	Stainless Steel, 1/4" FNPT, 3" Long.	200°C (400°F)	5000 PSIG	12 x 32mm, GF123270K, GF123270S
	SFA-H130S-TE	Stainless Steel, Heatable, 4.57" Long, 1/4" End Ports.	200°C (400°F)	30 PSIG	25 x 64mm, GF256470K, GF256470S
	SFA-137G	Glass Filter, T-Type, 1/4" FNPT, 4.49" Long.	200°C (400°F)	150 PSIG	25 x 64mm, GF256470K, GF256470S
	TFA-122P	PTFE, 1/4" FNPT, 3.86" Long.	150°C (300°F)	100 PSIG	12 x 57mm, GF125770K, GF125770S
	760N-2	Nylon, Side Ports, 1/4" FNPT, 5.51" Long.	50°C (120°F)	100 PSIG	25 x 64mm, GF256470K, GF256470S

Filters

Product	Description	Product	Description
GF123270K	Filter Cartridge, Borosilicate Glass Microfiber with Fluorocarbon Resin Binder, 12 x 32mm, Maximum Temperature 300°F, 10/pk.	GF256470S	Filter Cartridge, Borosilicate Glass Microfiber with Inorganic Binder, 25 X 64mm, Maximum Temperature 900°F, 10/pk.
GF123270S	Filter Cartridge, Borosilicate Glass Microfiber with Inorganic Binder, 12 x 32mm, Maximum Temperature 900°F, 10/pk.	GF125770K	Filter Cartridge, Borosilicate Glass Microfiber with Fluorocarbon Resin Binder, 12 x 57mm, Maximum Temperature 300°F, 10/pk.
GF256470K	Filter Cartridge, Borosilicate Glass Microfiber with Fluorocarbon Resin Binder, 25 X 64mm, Maximum Temperature 300°F - 10/pk.	GF125770S	Filter Cartridge, Borosilicate Glass Microfiber with Inorganic Binder, 12 x 57mm, Maximum Temperature 900°F, 10/pk.

OMNIFLOW FILTER HOLDERS

The Multi-Port Stainless Steel Filter Assembly has a 200°C (400°F) rating and is typically used for the filtering of combustion gases prior to analysis. The OmniFlow Filter Holder (N6) is spring loaded and designed for positive sealing. It features 6 ports (3 sample inlets, 1 calibration, 1 pressure and 1 sample exit). Each port is 1/4" FNPT (accepts 25" x 64" filters). *Cable entry seals sold separately.*



SFA-2564-4N6



SFA-2564-V2

Six Port Stainless Steel Filter Assembly
Accepts 25 mm x 64 mm Filter.

SFA-2564-4N6

Three 1/4" Port Stainless Steel Filter Assembly
Accepts 25 mm x 64 mm filter.

SFA-2564-V2...\$425.00

GAS SAMPLE FILTER ELEMENTS

Apex Instruments stocks two types of **Borosilicate Glass Microfiber Cartridges** to accommodate all particulate removal needs. For testing in locations where highly reactive and/or corrosive gases are present Apex offers the K-Type High Temperature with Fluorocarbon Resin Binders. The S-Type has low temperature cartridges with Inorganic Resin binders for filtering gases at temperatures up to 480°C (900°F).

GAS SAMPLE FILTER ELEMENTS

Product	Description: 10 per pack
GF123270K	12 mm x 32 mm, maximum temperature of 150°C (300°F)
GF125770K	25 mm x 57 mm, maximum temperature of 150°C (300°F)
GF256470K	25 mm x 64 mm, maximum temperature of 150°C (300°F)
GF2517870K	25 mm x 178 mm, maximum temperature of 150°C (300°F)
GF123270S	12 mm x 32 mm, maximum temperature of 480°C (900°F)
GF125770S	12 mm x 57 mm, maximum temperature of 480°C (900°F)
GF256470S	25 mm x 64 mm, maximum temperature of 480°C (900°F)

CONDENSERS

Apex Instruments **Stainless Steel Condensers** are designed to be submerged in an ice-water bath for condensing and removing water vapor prior to analysis. Use in conjunction with the peristaltic pump (see recommended pump below) to continuously remove the condensate. Condensers are recommended to be used in a series of two or more. *Custom-made condensers available please call for details on water jacketed condensers, chillers and appropriate pumps.*

Stainless steel condenser assembly with vessel, cap with Inner tube, clamp and gasket. Two 3/8" Ports and 1/4" drain tube.

SC-9A

Adapter, 3/8" button hook adapter for connecting condenser in series.

SC-9U

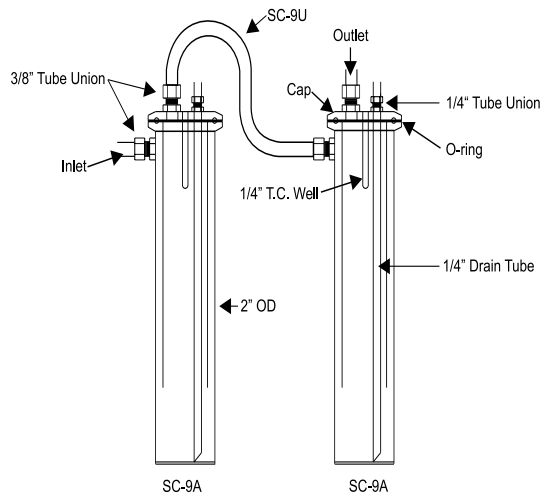

PERISTALTIC PUMP



The **Double-Headed Single-Speed Peristaltic Pump (PP927-049)** is ideal for removal of condensate from glass and stainless steel condensers. Each head provides a flow rate of 98cc/min. and can be used for two independent uses or combined when needed to increase the flow rate or pressure capability. Additional peristaltic pumps are available.

Single speed, dual head peristaltic pump, 49 rev/min, flow rate 98 ml/min per head.

PP927-049

Borosilicate Glass Condensers

Apex Instruments offers two types of borosilicate glass condensers. The products include caps and seals.



The **VGA-9A Condenser** is designed to be submerged in an ice-water bath for condensing water vapor. Glass condenser, coaxial design with 3/8" tube unions for inlet and outlet, 1/4" drain tube, 2" OD, 9" height.

VGC-9A



The **VGA-12A Condenser** allows the flow of ice water around the sample stream. Glass condenser with 3/8" tube unions for inlet and outlet, 1/4" drain on bottom, water jacket, 2" OD, 12" height.

VGC-12A

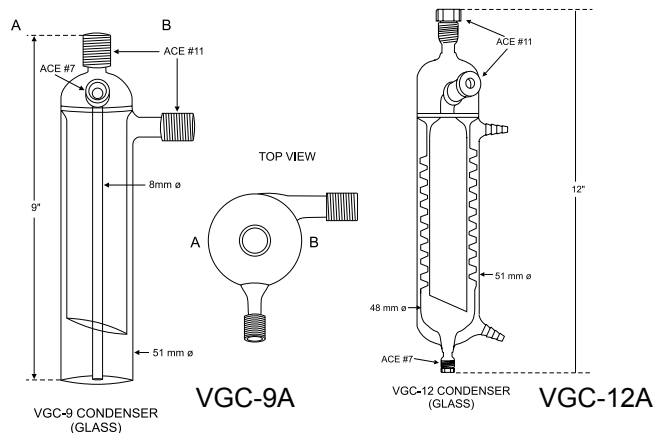

Product	Description
VGC-9	Glass Condenser-9" x 2" OD, 3/8" tube unions for inlet & outlet, 1/4" drain tube. NO SEALS.
VGC-12	Glass Condenser-12" x 2" OD, 3/8" tube unions for inlet & outlet, 1/4" drain tube, water jacket. NO SEALS.
VGC-12M	Glass Condenser-12" x 2" OD, with GL-18 threads for inlet, outlet & drain, threads accept 1/4" or 3/8" with proper seal, water jacket.
VGC-12MA	Glass Condenser-12" x 2" OD, with GL-18 threads for inlet, outlet & drain, threads accept 1/4" or 3/8" with proper seal, water jacket w/caps & seals.



Gas Analysis Equipment

Apex Dilution Panel	8c	Method 3, Orsat Analyzer	15c
Apex Flow Draw	12c	PMI Dilution Probe.....	8c
Combustion Gas Analyzers	16c	Pre-Filters	4c
Condensers	18c	Pro-Series Heated Sample Line	9c
Condensers, Borosilicate Glass	18c	Probe, Assemblies.....	5c
Filter Assemblies	6c	Probe, CEM.....	5c
Filter Holders	6c	Probe, IRM	4c
Gas Sample Filter Elements.....	6c	Probe, IRM Ceramic Heater	5c
Gas Conditioners.....	11c	Probe, Stainless Steel Liners	5c
Gas Analyzers	13c-14c	Pumps, Peristaltic.....	18c
Gas Sample Filter Housing.....	17c	Temperature Controllers.....	10c
Gas Sample Filter Elements.....	17c	Tri-Sample Probe	7c
IRM, Transportable IRM System	3c		



APEX INSTRUMENTS, INC.

Solutions for Source Sampling Equipment

Apex Instruments is a world leader in the manufacture, design and distribution of source sampling equipment. Our products are used in a wide variety of sampling scenarios. Our equipment complies with emissions measurement standards for stationary combustion sources in accordance with US EPA guidelines. We are located approximately 20 miles from the United States Environmental Protection Agency in Research Triangle Park, N.C. Our goal is to provide you with the proper, well engineered equipment in order for your job to run smoothly and have consistent, accurate and reliable results.

TECHNICAL SERVICES

Apex Instruments understands the needs and high demands of the individuals working in the source sampling industry. The primary end users of our equipment consist of government agencies, consulting firms and private industries throughout North America and in 50 countries around the globe. Our knowledgeable staff includes many skilled industry professionals, stack testers and chemists. They all will help you to make important decisions regarding your specific application needs.

CALIBRATION SERVICES

Apex Instruments offers dedicated, climate controlled, precision calibration services for a variety of measuring instruments. This includes gas meters, orifices and pitot tubes to help keep all your calibration equipment up-to-date. Our trained staff will utilize the reliable calibration equipment and tools such as NIST Certified Bell Prover wet test meters, electronic flow calibrators and wind tunnels. We offer a certification of calibration when requested.

CUSTOM FABRICATION AND ASSEMBLY

Apex Instruments' custom-designed facility was built in 2005. The warehouse layout provides a smooth flow for the assembly and fabrication departments. We can design, build and expedite all equipment orders quickly through our in-house engineering, production and welding departments. Apex continues with their steady commitment to quality in compliance testing, by consistently designing and developing reliable source sampling equipment. We follow guidelines set by U.S. EPA Reference Methods and always keeping the genuine needs of the stack samplers in mind.

AWARDS

Apex Instruments recently received the (SHARP) Safety and Health Achievement Award from the NC (DOL) Department of Labor. This program recognizes small to medium size businesses that establish and maintain effective safety standards and health programs. We were also ranked in the top 500 by Inc. Magazine as being one of the fastest growing privately held companies.

TERMS AND CONDITIONS

PRICES AND TERMS

Our prices are subject to change without notice. The price in effect when we receive your order will apply. All prices are Ex Works Holly Springs, North Carolina. We will be pleased to furnish quotations by phone, fax or e-mail. Terms of payment are Net 30 days with established credit, or by Visa/MasterCard/American Express at time of order. Invoices over 30 days past due are subject to 1.5% permonth finance charge.

CONFIRMING ORDERS

Please make sure that all confirming orders are clearly marked to avoid duplicate orders.

SHIPMENTS AND DELIVERY

Unless otherwise instructed, shipments are made as soon as possible after receipt of order by method of transportation which in our judgement will be most satisfactory. Freight charges are prepaid and added to the invoice. The right is reserved to make partial shipments where delays beyond our control may delay a portion of the order.

EXPORT PROCESSING AND PRICING

Prices do not include customs and duty charges, freight, insurance, export fees, bank wire transaction fees or any additional handling fees.

RETURNED ITEMS

Authorization must be obtained from us before returning any goods. When requesting return authorization, please advise reason for return, date of purchase, your P.O. number and our invoice number. Equipment produced to special specifications are not returnable. All returns must be shipped freight prepaid at the purchasers expense and are subject to a restocking fee.

LIMITED WARRANTY

APEX INSTRUMENTS, INC. warrants products to be free from defects in workmanship for a period of one year from date of delivery. The sole and exclusive remedy for defective goods shall be to repair or replace defective parts or payment price of the goods for which damages are claimed at APEX INSTRUMENTS, INC.'s option. Freight for return of defective items will be at the sole discretion of APEX INSTRUMENTS, INC. Except as described in our guarantee, there are no express warranties or implied warranties including, but not limited to, merchantability and fitness for a particular purpose. APEX INSTRUMENTS, INC. shall not be subject to and disclaims: (1) any other obligations or liabilities arising out of breach of contract or warranty, (2) any obligations whatsoever arising from tort claims (including negligence and strict liability) or arising under other theories of law with respect to products sold or services rendered by APEX INSTRUMENTS, INC., or any undertakings, acts or omissions relating thereto, and (3) all consequential, incidental and contingent damages whatsoever.

DESIGN CHANGES

Design changes are made from time to time. Some items may differ slightly from catalog illustrations or descriptions. Changes are made in the interest of better performance and quicker delivery.

ACCEPTANCE OF TERMS AND CONDITIONS

APEX INSTRUMENTS, INC. sells products only under foregoing terms and conditions and will not be bound to terms and conditions stated by any purchaser in any offer, acceptance or other contractual document. Placing an order or accepting delivery of products constitutes acceptance of terms and conditions.

Great care has been taken in preparation of this literature, however, we cannot be responsible for any omissions or typographical errors.

204 Technology Park Lane
Fuquay-Varina, North Carolina 27526, U.S.A.
Telephone: 919-557-7300
In U.S. Call: 800-882-3214
Fax: 919-557-7110
Email: info@apexinst.com



Filters

Flanges

Pre-Filter

2011

**GAS ANALYSIS
EQUIPMENT
CATALOG**

Publication: PEC-Gas
Date Issued: 12-10-10